



M Cube

Microphone System

for 3D recordings in
time delay stereophony

MOUNTING SYSTEM Parts and Instructions

- condenser microphones
- omni-directional
- measurement quality capsules
- nickel diaphragms
- transistor pre-amplifier
- phantom powering P48

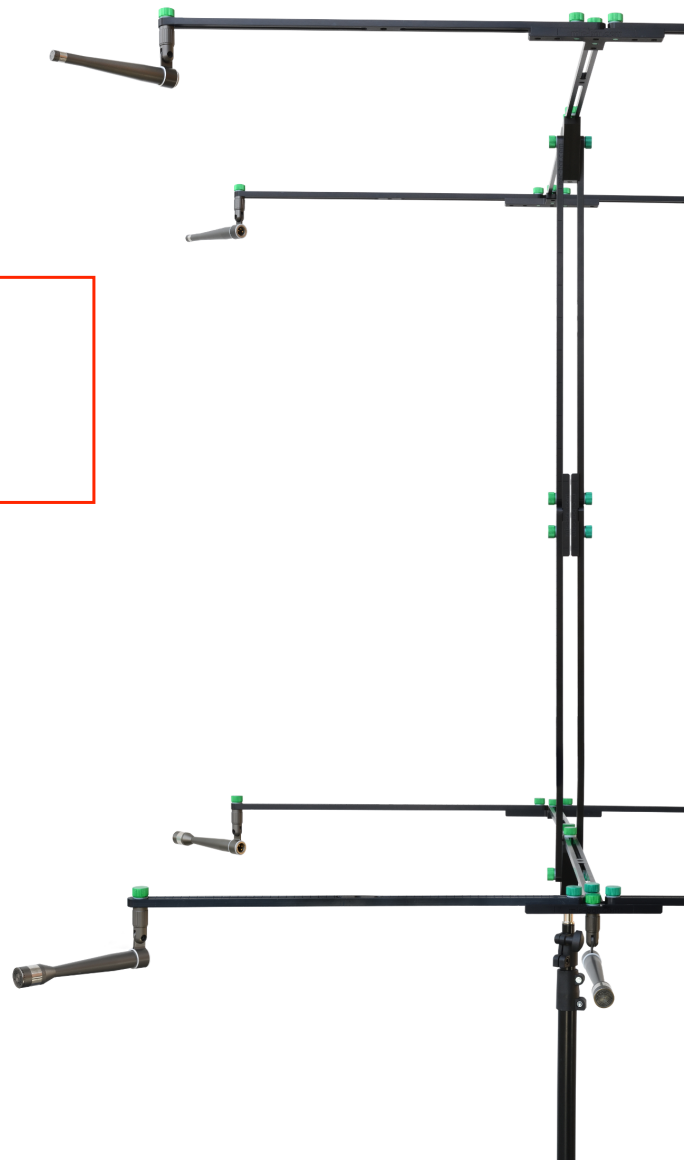

Scope of delivery part # 1

Article-No.: 610202

Microphone bar system for 3D-Array 9.0

16 pieces microphone bar base AB, 57 cm black anodised

4 pieces microphone bar T-piece, black anodised, incl. 2 screws

2 extension pieces for microphone bar, black anodised, inkl. 2 screws

2 connection pieces for 3D-array 9.0, black anodised



Scope of delivery part # 2

Article-No.: 2111199

Microphone-System for 3D-Array 9.0 dark bronze
incl.

4 microphone capsules MK221 dark bronze

5 microphone capsules MK102 dark bronze

5 adaptors 1" to 1/2" A63 dark bronze

9 microphone preamplifiers MV225 dark bronze

4 acoustical equalization balls KA3

4 acoustical equalization balls KA3

1 Suitcase 1 for 3D-9.0

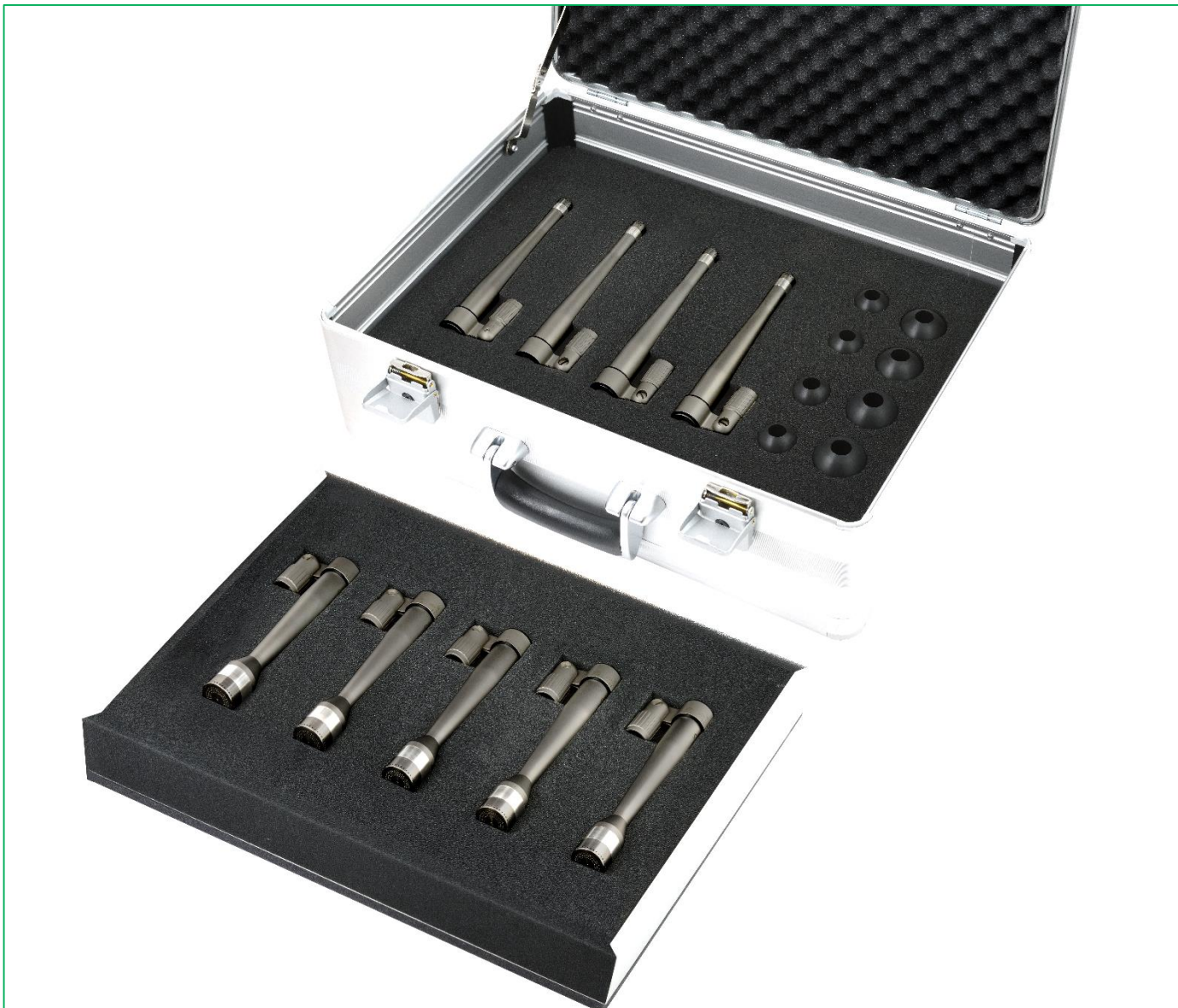

Chronological order /assembly recommendation

1. Middle section (# A)
2. Second level (# B)
3. First level (# C)
4. Tripod

A



Article-no.: 600216
connection pieces for
3D-array 9.0, black
anodised

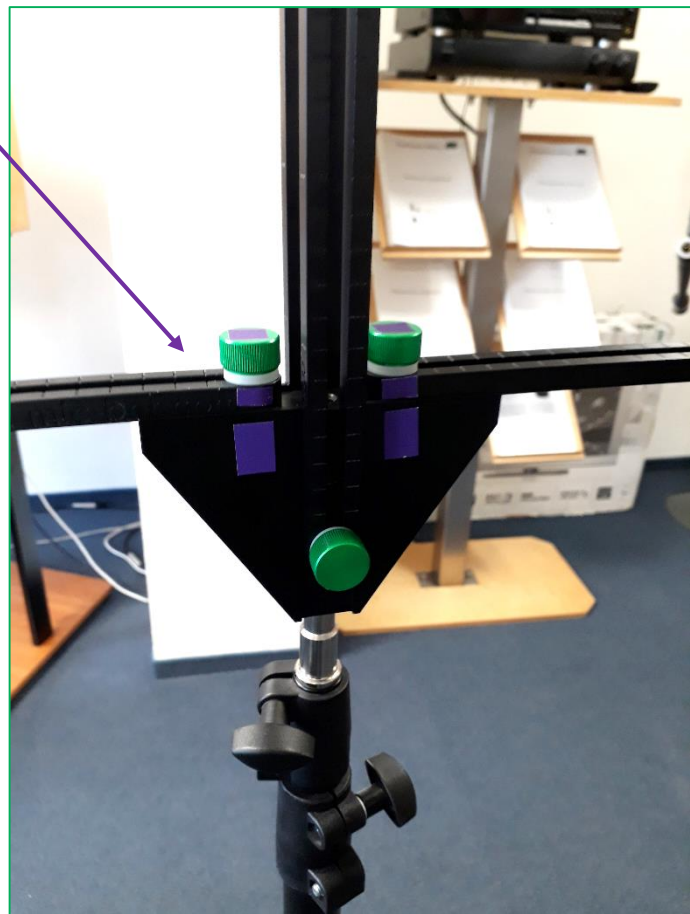
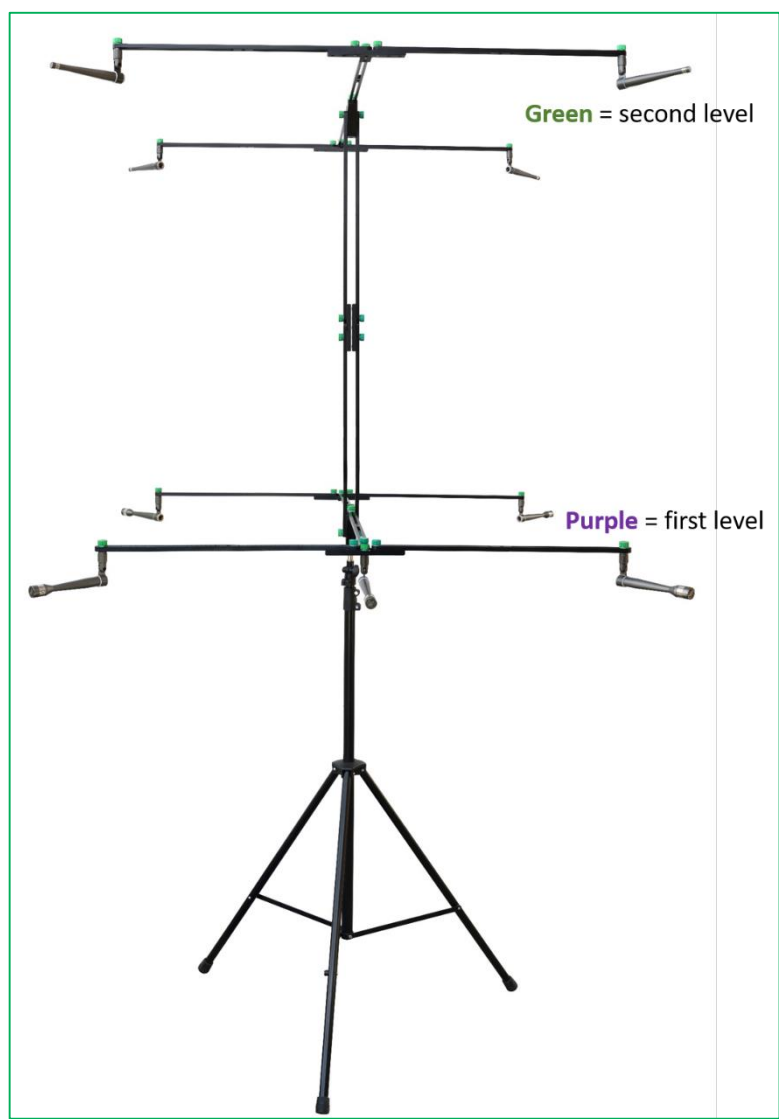
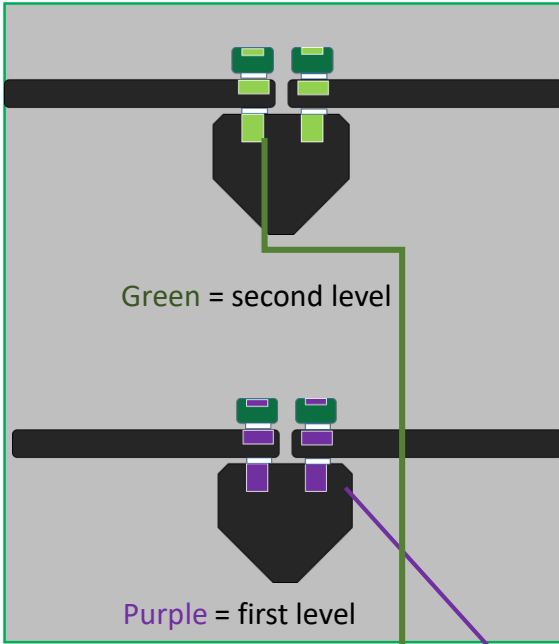

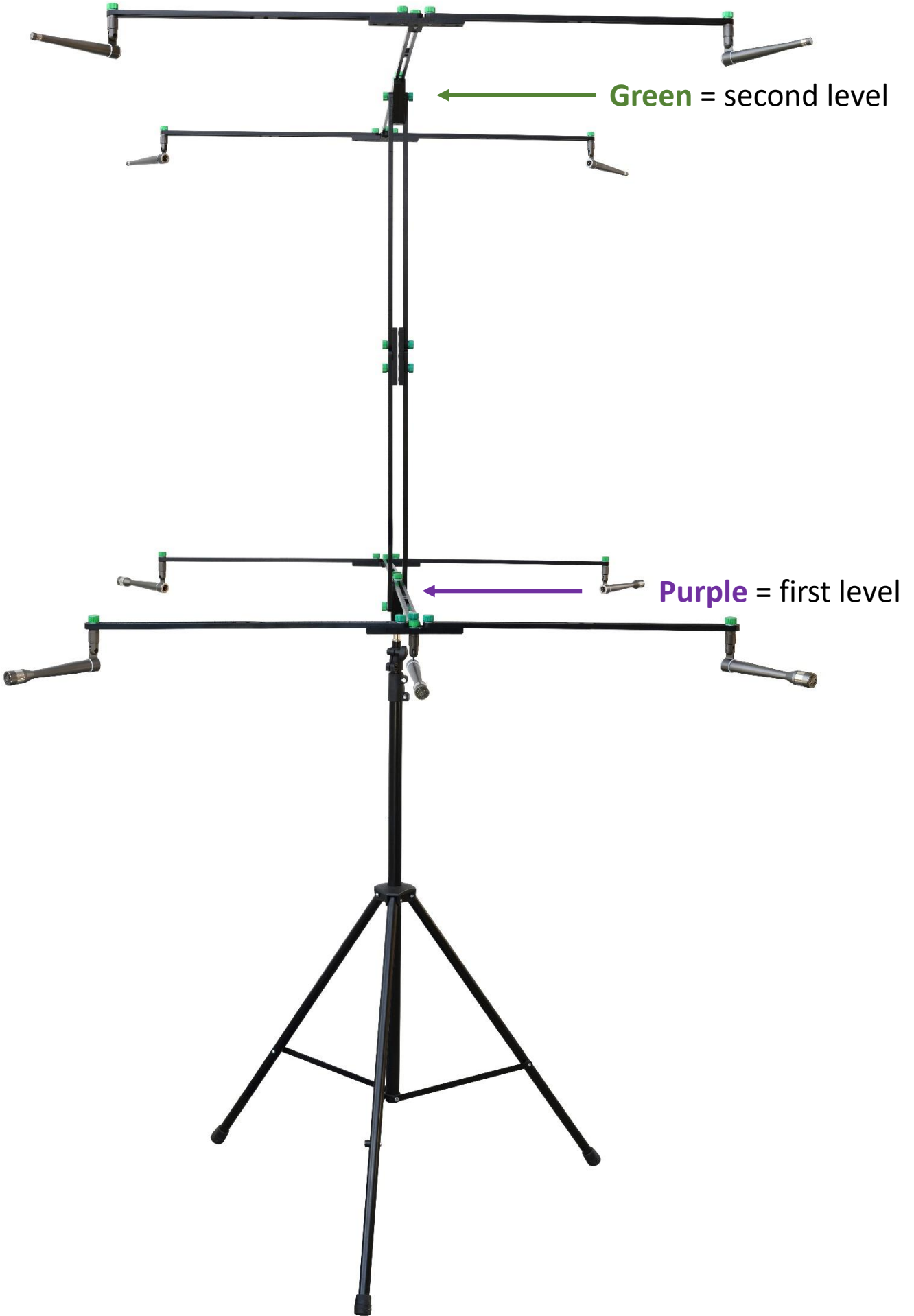

Green = second level

Purple = first level

Green = second level (#B)



Purple = first level (C)



