

musikelectronic geithain



Active Bass Loudspeaker
BASIS 2



musikelectronic geithain



The Reference Class - Active Studio-Monitors made by musikelectronic geithain

RL Series

From a compact two-way monitor up to large loudspeaker-systems - we provide you with the best solutions for all kinds of professional use. The RL series' studio-monitors are the result of consequent development that needed many years and pursued only one aim: the highest degree of precise sound without any coloration regardless of genres. Hearing and measuring are the basis of our work. We build on profound musical comprehension and the knowledge of unalterable physical laws - not on magic tricks, new fashioned ideas nor marketing-strategies.

You have to do it you yourself!

We produce loudspeaker in accordance to our conviction. That is why we develop and construct all

monitors ourselves - from A to Z, from the electronics of the amplifier to the voice coil of the transducer. A product, which components all come from our own manufacturing, has noticeable advantages for you as a professional customer. We are independent of third parties products and build our components just the way we require them - this proceeding can't be beaten in quality by mass-production. This strategy also leads to high continuity and a fixed (stable) value of our product range as well as it ensures that replacement parts will be available for long-term. We believe that this is the only way to create a product which is worth your investment and satisfies your professional needs for many years.

Active Bass Loudspeaker BASIS 2

The active bass loudspeaker BASIS 2 serves its purpose to complement lower octaves to the RL903, RL904, RL906 studio monitors and also as the main sub-woofer for 5-channel audio playback. The speaker is fully equipped with all necessary connections; so it allows a flexible integration in surround-sound systems. Not only the three front channels left, middle, and right but also both rear surround-channels pass through a High-pass filters at 80 Hz. All 5 channels lower frequency range and the LFE-signal are added up, whereat the LFE-signal can be adjusted separately. The BASIS 2 features by phase correction. In a range from 0 to 1 meter the distance between the plane of the front speaker's radiation and the BASIS 2 can be compensated. A switch enables a HPF to limit the frequency response from 28 Hz to 40 Hz. The power amplifier is designed on MOSFET-technology. A frequency-dependent protection with RMS detection keeps the

driver from overloads. A specially developed long-throw bass driver, which is able to linear displacement of ± 12 mm, ensures a low-frequency transducing with very low distortion by this way the localization of the sub-bass in the room minimized. To achieve the optimal characteristics of the puls we use a closed cabinet for the loudspeaker. The system can be set in a bypass-mode by using a cable-connected remote-control. Thereby all 5 output channels get routed directly to their input signals - the bass channel is disconnected. The control- and the power-unit as well as all connections and controllers are attached to the cabinet's backside. A two-colored LED on the front side indicates the state of the amplifier and warns of clipping. We optionally offer the speaker in a magnetically-shielded version. For the use in mobile broadcast vans or for frontal installations in a wall we also supply all the electronics in a separate box.

Specifications

General	Complement of low frequencies for the reproduction of the multi channel formats 2/0; 3/2; 5.1; 7.1 and Dolby Surround(3/1)
Maximum SPL	116 dB / r =1m; 2p
Bandwidth with HPF	28 Hz...80 Hz; 2p 40 Hz...80 Hz; 2p
Inherent noise sound level	GK0 / DIN 15996 r =1m
Total harmonic distortion / measured at 96 dB / r =1m; 2p; 40 ... 90 Hz	K ₂ f -25dB, K ₃ f -34dB
Nominal input level L, M, R, SR, SL LFE-channel	+6 dBu (adjustable) -4 dBu (adjustable)
Output level L, M, R, SR, SL	+6 dBu / 2 kOhm / symmetrically
Input impedance	³ 10 kOhm / symmetrically
Bass-output level	adjustable
Nominal output power of the MOSFET-amplifier	400 Watt / 4 Ohm
Electronic crossover frequencies	LPF 24 dB/Okt. f _t = 80 Hz HPF 12 dB/Okt. f _t = 80 Hz
Distance compensation	adjustable from 0...1 m difference to the front speaker's plane
Operation and clipping indicator	LED on front side
Input connector	5 x XLR 3F
Output connector	5 x XLR 3M
Connector for bypass-mode switch	XLR 4M
Loudspeaker systems	280 mm cone
Temperature requirements for use	+15°C to +35°C
for storage	-25°C to +45°C
Humidity	45 - 75 %
Power requirements	Europe 230 Volt (±10%), AC, 50 Hz U.S.A. & Canada 127 Volt, AC, 60 Hz
Power consumption	max. 700 Watt at full load
Dimensions (H x W x D)	456 x 670 x 390 [mm]
Weight	50 kg
Design of the Cabinet optional	MDF wood, black veneer, different colors
Magnetic shield	optional

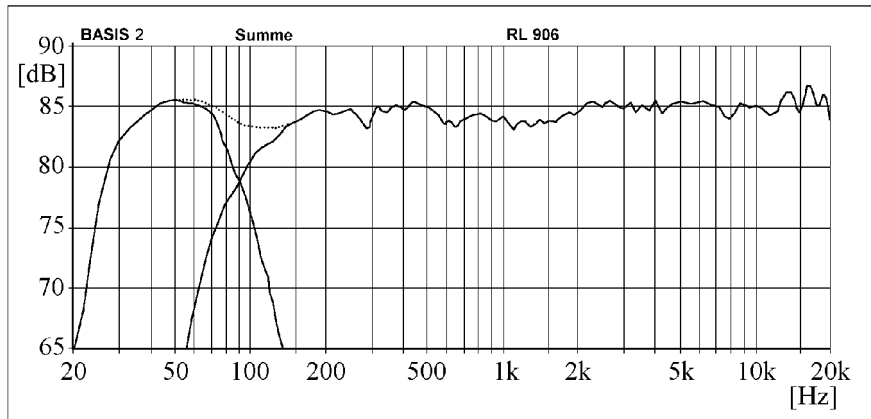

Freifeldübertragungskurve

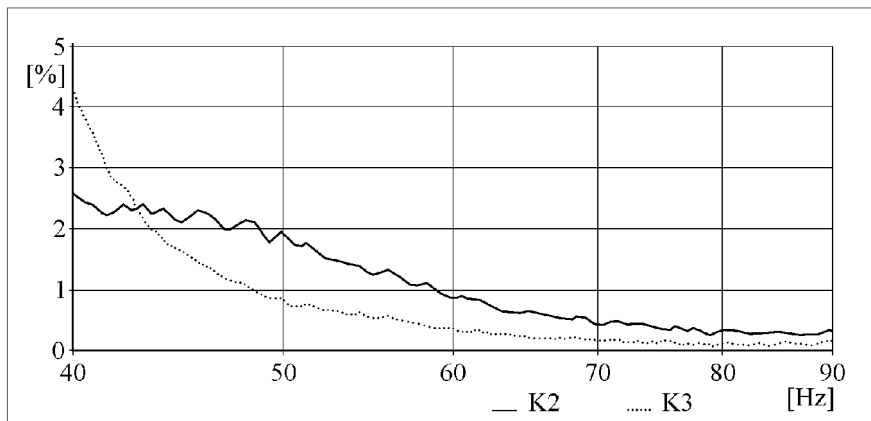

Klirrkompenten $P_A = 96$ dB

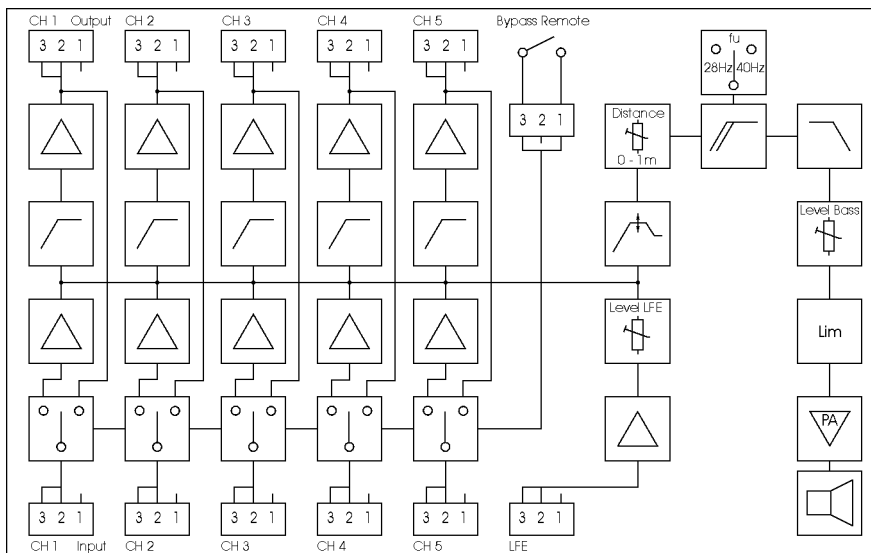

Blockschaltbild



musikelectronic geithain gmbh

STUDIOTECHNIK - BESCHALLUNGSTECHNIK

Nikolaistrasse 7

04643 Geithain

Germany

Tel: (+49) 34341 3110

Fax: (+49) 34341 31144

e-mail: info@me-geithain.de